



## ROPOX NURSING TABLES

SAFE AND  
A PLEASURE TO USE!



**When the feeling of confidence is an important factor.....**  
Nursing becomes more pleasant when you are confident and in safe hands.  
Therefore, our nursing tables have been developed to meet the requirements of current standards and directives.

# ROPOX NURSING TABLES OFFER

- **Improved working environment** - The clever offset design of the table allows you to stay close to the surface and shelves with improved working postures. The child can be laid in different positions as the nursing area is surprisingly large.
- **Improved safety** - the rounded design protects the child from sharp corners and edges.
- **Better hygiene** - the smooth and rounded surfaces facilitate cleaning of the table.
- **Space optimisation** - The curved front and offset wall frame give more changing space without intruding into the room. The unit fits easily below windows (min free height 102 cms) and has plenty of space below the table to locate electrics and plumbing.



## OUR HEIGHT-ADJUSTABLE NURSING TABLES ARE AVAILABLE IN TWO MODELS



Maxi2



Medi2

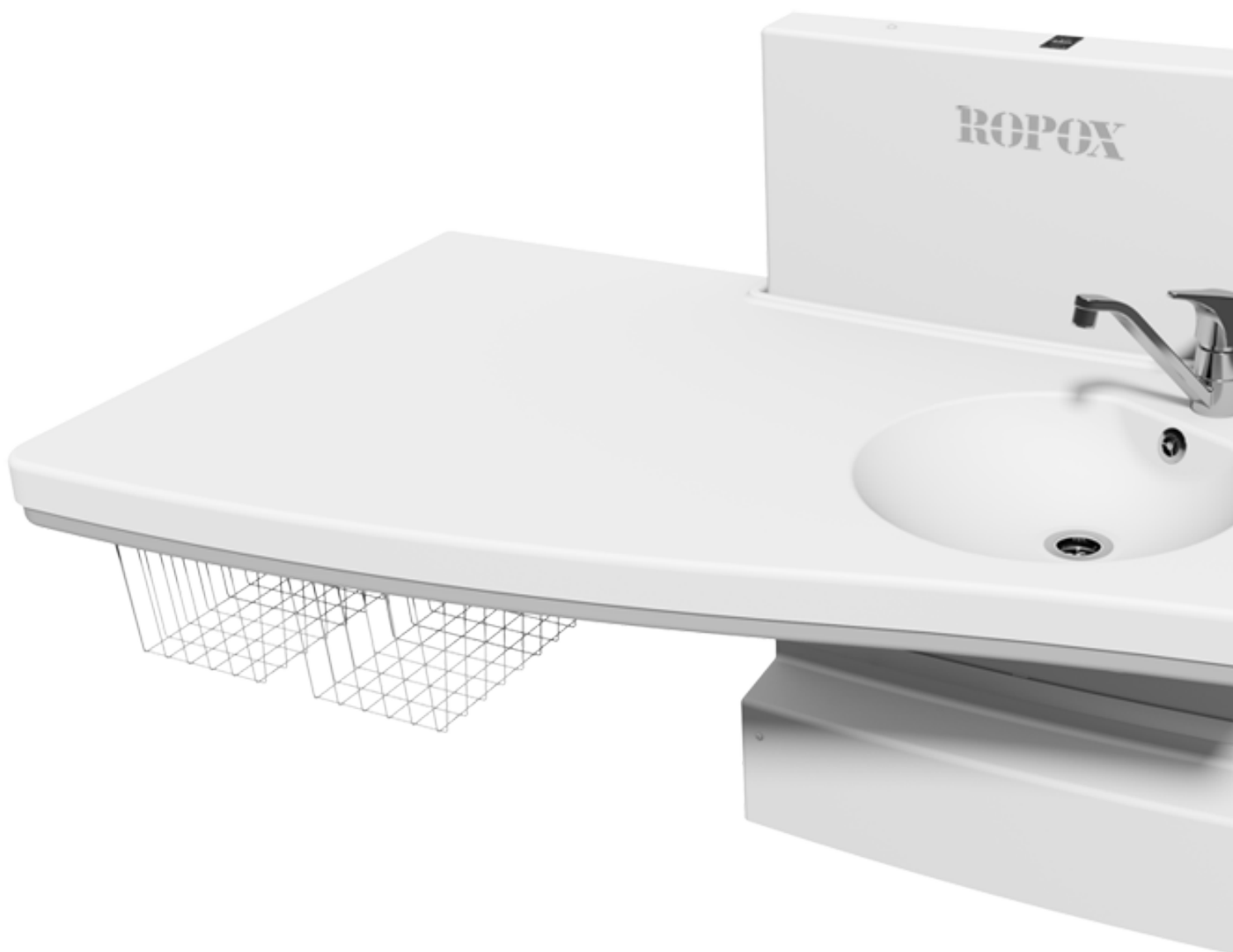

## VERSIONS

**MAXI2**  
#50-50670

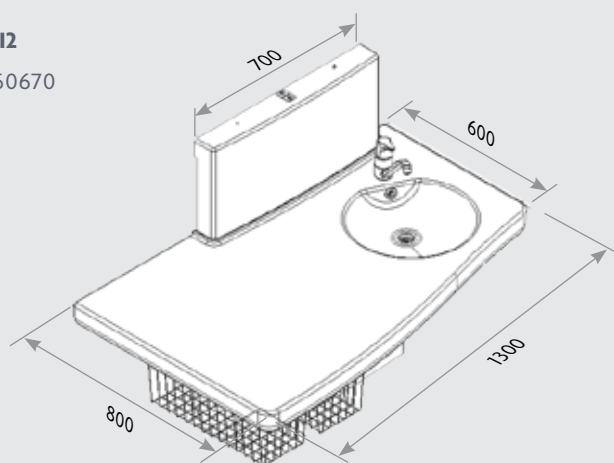

**MAXI2**  
#50-50672

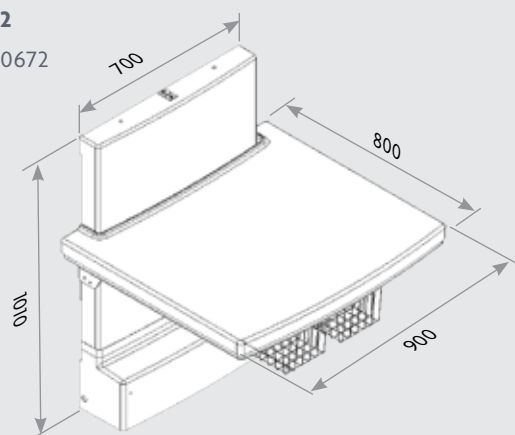

# ROPOX

## HEIGHT-ADJUSTABLE NURSING TABLE - MODEL MAXI 2



**Unique design of the nursing table** - The design offers improved working postures. Owing to the special shape of the front you may get closer to the wall and shelves. This makes the available space feel larger - you are standing "inside" the table.

The child may be placed diagonally on the mattress to utilise the width.



**Integral safety stop offering improved safety** – If the table meets an obstacle during height adjustment, the movement will stop immediately. This is an important safety factor.

### MATERIAL

VACUUM-SHAPED PLASTIC  
ALUMINIUM  
COATED STEEL  
STAINLESS STEEL

### LOAD

75 KG

### FUNCTIONAL DIMENSIONS

HEIGHT ADJUSTMENT 400-1000 MM

### Ropox nursing table - Model Maxi 2

This nursing table is ideal for use in existing and new institutions.

Owing to the unique design and integral sink, the nursing table is very functional and extremely easy to clean.

The table may be lowered to the floor for the child to climb onto it without help.

## ACCESSORIES

### SIDE COVER

#50-50682 / #50-50683

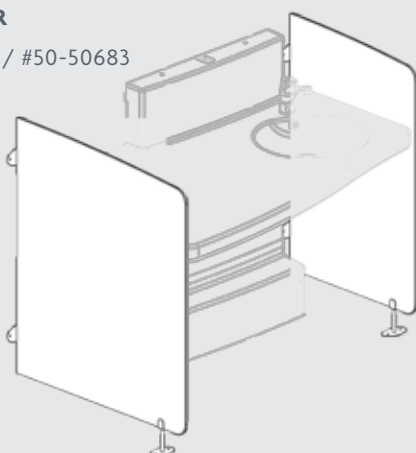

### ADAPTER FRAME

#50-50685/ #50-50686

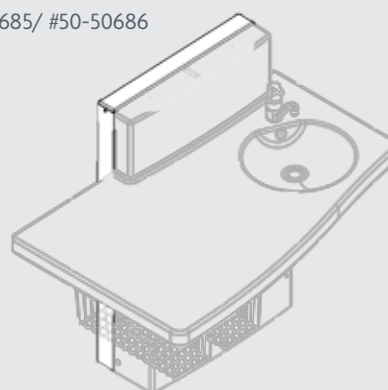

### MATTRESS

#50-50680 / #50-50681

### NO-TOUCH MIXER TAP

#50-14684

### MIXER TAP WITH TELESCOPIC HAND SHOWER

#50-50694

### HAND CONTROL

#50-50690



## VERSIONS

**MEDI2**  
#50-50675

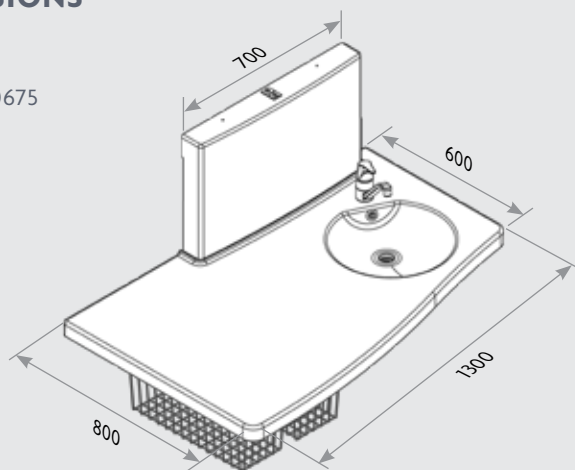

**MEDI2**  
#50-50677

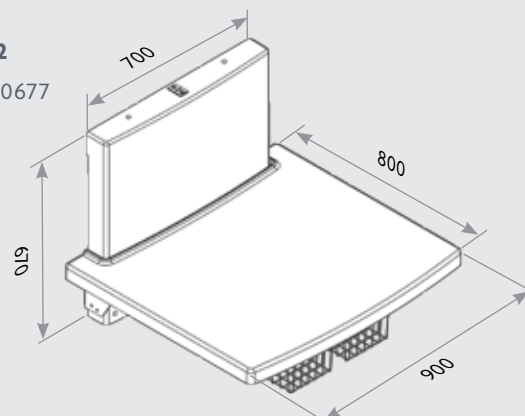

# ROPOX

## HEIGHT-ADJUSTABLE NURSING TABLE - MODEL MEDI 2



**Unique design of the nursing table** - The design offers improved working postures. Owing to the special shape of the front you may get closer to the wall and shelves. This makes the available space feel larger - you are standing "inside" the table.

The child may be placed diagonally on the mattress to utilise the width.



**Optional integral safety stop for improved safety** - If the table meets an obstacle during height adjustment, the movement will stop immediately. This is an important safety factor.

### MATERIAL

VACUUM-SHAPED PLASTIC  
ALUMINIUM  
COATED STEEL  
STAINLESS STEEL

### LOAD

75 KG

### FUNCTIONAL DIMENSIONS

HEIGHT ADJUSTMENT 650-1000 MM

### Ropox nursing table - Model Medi 2

This nursing table is ideal for use in existing and new institutions.

Owing to the unique design and integral sink, the nursing table is very functional and extremely easy to clean.

The table may be lowered to the floor for the child to climb onto it with a ladder.

## ACCESSORIES

### SIDE COVER

#50-50682/ #50-50683

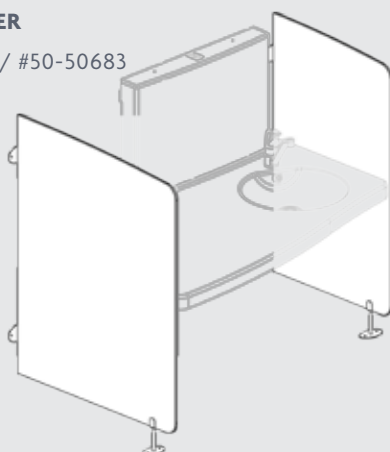

### ADAPTER FRAME AND SUPPORT FEET

#50-50689/ #50-50687



### SAFETY STOP

#50-50691 / #50-50692

### MATTRESS

#50-50680 / #50-50681

### MIXER TAP NO-TOUCH OR WITH TELESCOPIC HAND SHOWER

#50-14684 / #50-50694

### THREE-STEP LADDER

#50-25703

### HAND CONTROL

#50-50690

# ABOUT ROPOX

For more than 50 years, Ropox has developed a wide variety of products for functionally disabled persons and therefore possesses thorough knowledge of subjects relating to accessibility and working environment.

For further information, please contact Ropox or one of our distributors  
– [www.ropox.com](http://www.ropox.com)



## ROPOX TABLE PRODUCTS

ELEGANT HEIGHT-ADJUSTABLE TABLES DESIGNED TO SUIT INDIVIDUAL NEEDS

## ROPOX KITCHEN PRODUCTS

FLEXIBLE AND HEIGHT-ADJUSTABLE KITCHEN SOLUTIONS

## ROPOX BATHROOM PRODUCTS

INNOVATIVE AND ATTRACTIVE PRODUCTS FOR NUMEROUS COMBINATIONS

ROPOX A/S · RINGSTEDGADE 221 · 4700 NÆSTVED, DENMARK  
TEL.: +45 5575 0500 · [INFO@ROPOX.DK](mailto:INFO@ROPOX.DK) · [WWW.ROPOX.COM](http://WWW.ROPOX.COM)

**ROPOX**<sup>TM</sup>  
BETTER WAYS TO BETTER DAYS